

HPP设备

HPP EQUIPMENT

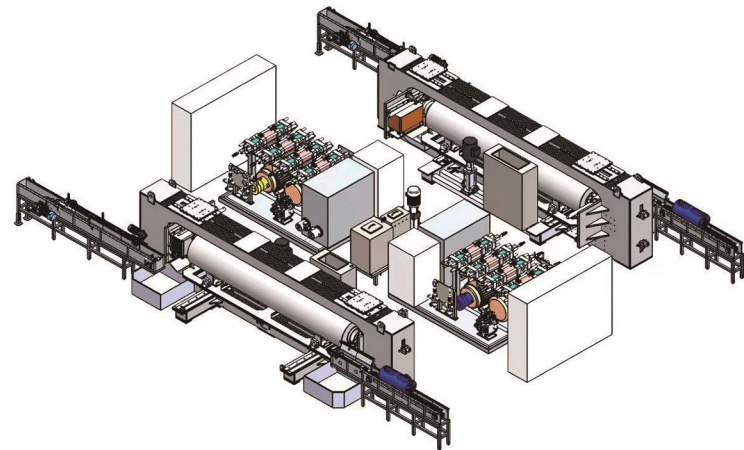
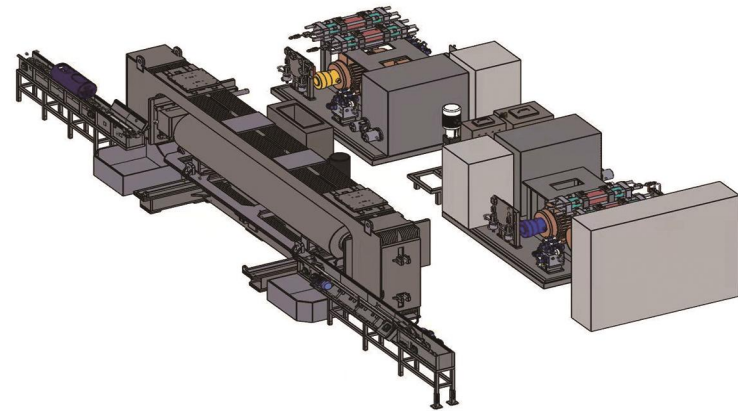

上海威正达智能科技有限公司

Shanghai Victorystar Intelligent Technology Co.,Ltd

地址/address:上海市奉贤区/Fengxian District, Shanghai City, China

电话/Whatsapp: +86 136 1178 1699 邮箱/Email: jack@shvictorystar.com

网址/Website: <http://www.weystartech.com> <http://en.weystartech.com>

HPP设备

HPP EQUIPMENT



HPP设备

HPP EQUIPMENT

HPP设备是一种利用超高压技术进行食品灭菌的设备，它能够在不加热的情况下保留食品的原始口味和口感，同时延长食品的保质期。这种技术通过在0~600MPa的高静水压力条件下处理食品，利用细菌微生物在超高压环境中失活的特性，达到杀菌、钝酶和加工食品的目的。HPP设备的主要特点包括：

HPP ultra-high pressure pasteurization equipment can preserve the original taste and texture of food without heating, while extending the shelf life of food. This technology treats food under high hydrostatic pressure conditions of 0 to 600 MPa, using the characteristics of bacterial microorganisms being inactivated in an ultra-high pressure environment to achieve the purpose of pasteurization, enzyme inactivation and food processing. The main features of HPP equipment include:

杀菌效果 Pasteurization effect

HPP技术能够在不破坏食品营养成分和风味的前提下，杀死食品中的细菌、霉菌和酵母菌，从而延长食品的保质期。

HPP technology can kill bacteria, molds and yeasts in food without destroying the nutritional components and flavor of the food, thereby extending the shelf life of the food.

设备结构 Equipment structure

HPP设备通常采用全封闭式结构，全自动生产线，适用于预制菜品、果汁果泥、二次加工肉类产品等的杀菌。

HPP equipment usually adopts a fully enclosed structure and a fully automatic production line, which is suitable for pasteurization of pre-prepared dishes, juice puree, secondary processed meat products, etc.

技术参数 Technical Parameters

设备的工作压力通常在0-600MPa，启动时间和卸压时间较快。

The working pressure of the equipment is usually 0-600MPa, and the startup time and pressure relief time are relatively fast.



适用范围 Scope of application

适用于果汁果泥、肉类及二次加工产物（如香肠、肉酱）、牛奶以及腌渍菜预制菜类等，理论上水分不低于72%的食品都可以进行超高压灭菌。

Suitable for fruit juice puree, meat and secondary processed products (such as sausage, meat sauce), milk, pickled vegetables and pre-prepared dishes, etc. Theoretically, any food with a moisture content of not less than 72% can be sterilized by ultra-high pressure sterilization.

设备规格 Equipment specifications

单体型：2L-500L，双体型：2X100L-500L，根据客户不同产品性能及产量定制，满足客户不同需求。

Single system type: 2L-500L, dual system type: 2X100L-500L, customized according to the performance and output of different products of customers to meet different needs of customers.

安全特性 Safety Features

HPP设备在设计上考虑到了安全性能，包括但不限于密封的安装结构、适当的温度和湿度范围、以及必要的通风和散热措施。

HPP equipment is designed with safety in mind, including but not limited to a sealed installation structure, appropriate temperature and humidity ranges, and necessary ventilation and heat dissipation measures.

此外，HPP技术的应用不仅限于食品工业，还包括医疗、药品等领域，展现了其在保持产品原始特性方面的独特优势。随着技术的进步和应用领域的扩展，HPP设备将继续在保持食品安全和品质方面发挥重要作用。

In addition, the application of HPP technology is not limited to the food industry, but also includes medical and pharmaceutical fields, showing its unique advantages in maintaining the original characteristics of products. With the advancement of technology and the expansion of application fields, HPP equipment will continue to play an important role in maintaining food safety and quality.

